

- » Sleek design with NEW 18 mm width in accordance with DIN norm
- » Conforms to IEC 61812-1+ UL 508
- » Wide power supply range (12-240 V AC/DC)
- » SPDT relay output (10A)
- » Wide and easily adjustable time range
- » LED notifications
- » High sensitivity and switching capacity
- » High mechanical endurance

STEP 1

Model Name	Order No	Mode	Relay Count	Time Range
Z1A-ND30s	261025	ND	1 C/O	1 sec .. 30 sec
Z1A-ND100s	261023	ND	1 C/O	1 sec .. 100 sec
Z1T-ND100s	261010	ND	1 C/O	1 sec .. 100 sec
Z1T-PFD120m-24	261011	PFD	1 C/O	1 sec .. 120 min
Z1T-PFD120s-24	261030	PFD	1 C/O	1 sec .. 120 sec
Z1T-NDX	261012	ND	1 C/O	0 sec .. 5109 sec
Z1T-FDF	261013	FDF	1 C/O	0.1 sec .. 10 days
Z1T-NDF	261014	NDF	1 C/O	0.1 sec .. 10 days
Z1T-ND100s.2	261026	ND	2 C/O	1 sec .. 100 sec



<b>Operating Voltage</b>	12..240V AC/DC ±10% 24..240V AC/DC ±10% (for Z1T-PFD120m-24, Z1T-PFD120m/s-24) 24V AC/DC (A2-A3 ve 180 .. 265V AC (A1-A3) (for Z1A-xxx)
<b>Operating Frequency</b>	45..65Hz
<b>Power Consumption</b>	DC < 1.5 W < 8 W (for Z1T-PFD120m-24) AC < 5 VA < 8 VA (for Z1T-PFD120m-24)
<b>Relay Outputs</b>	Maximum Switching (Voltage/Current/Power) 115VAC / 10A / 1250 VA    250VAC / 5 A / 1250 VA 250VAC / 16A / 4000 VA (for Z1T-PFD120m/s-24)
<b>Cable Cross Section</b>	2.5mm <sup>2</sup> / AWG 14-30 solid or stranded
<b>Screw Tightening Torque</b>	0.5 Nm / 4.5 lb-inch
<b>Cable Stripping Size (Min / Max)</b>	8mm / 9mm
<b>Operating Temperature Range</b>	-20 / +60 °C
<b>Max Surrounding Air Temperature</b>	60°C (55°C for Z1T-PFD120m/s-24)
<b>Protection Degree (IEC 60529)</b>	IP 20
<b>Pollution Degree</b>	2

NOTE: The charging time of the Z1T-PFD120m-24 product varies between 3 seconds and 1 minute, and the charging time of the Z1T-PFD120s-24 product varies between 3 and 10 seconds.  
NOTE: Use 60/75°C copper (CU) wire only.

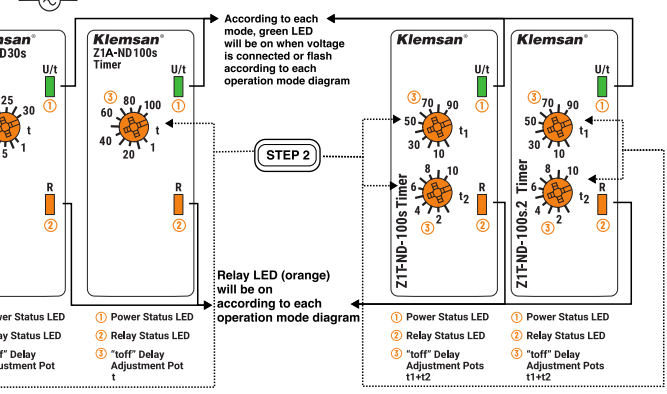
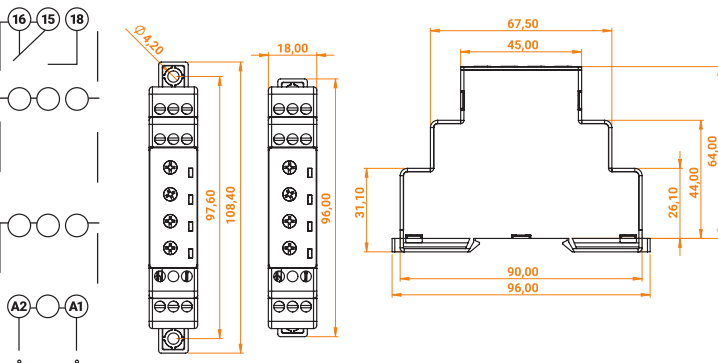

STEP 1

OPERATION MODE	FUNCTION ILLUSTRATION	FUNCTION STATEMENT
<b>Mode: ND</b> On Delay		The output relay is initially de-energized and energized after an adjustable time delay, t <sub>off</sub> .
<b>Mode:FDF</b> OFF Flash		The output relay is initially de-energized and energized after an adjustable time delay, t <sub>off</sub> , and stays energized for an adjustable period, t <sub>on</sub> , and then de-energized. This loop is repeated until the device is powered off.
<b>Mode:NDF</b> ON Flash		The output relay is initially energized and de-energized after an adjustable time delay, t <sub>on</sub> , and stays de-energized for an adjustable period, t <sub>off</sub> , and then energized. This loop is repeated until the device is powered off.
<b>Mode:PFD</b> Power-Off Delay		The output relay is initially energized and the device starts to charge. When the device is power off, the output relay remains energized until the adjusted time. The loop starts again when the device is power on.

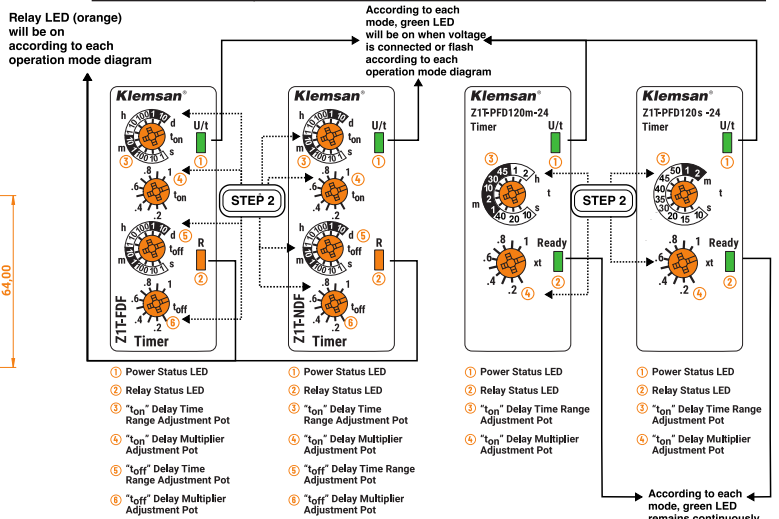

**SETTING THE TIMER RELAY** Z1T-FDF Z1T-NDF Z1T-PDF120m-24 Z1T-PDF120s-24

**STEP 1** Check the device model name and understand which operating modes your device supports.

**STEP 2** Set time range from the pots No.3, No.4, No.5 and No.6 in Z1T-FDF Z1T-NDF Set time range from the pots No.3 and No.4 in Z1T-PDF120m-24 Z1T-PDF120s-24

Example → For t<sub>on</sub> = 100 seconds → Set pot no.3 to 100s and pot no.4 to 1  
Example → For t<sub>off</sub> = 50 seconds → Set pot no.4 to 100s and pot no.4 to .5 (Z1T-FDF Z1T-NDF)  
Example → For t = 45 minutes → Set pot no.3 to 45m and pot no.4 to 1 (Z1T-PDF120m-24)  
Example → For t = 45 seconds → Set pot no.3 to 45s and pot no.4 to 1 (Z1T-PDF120s-24)

Please disconnect the power before adjusting the timers, device will start with the new settings after connecting the power

orange LED will be on when the relay is activated

**USER ASSISTANT**

**SETTING THE TIMER RELAY** Z1A-ND30s Z1A-ND100s Z1T-ND-100s Z1T-ND-100s.2

**STEP 1** Check the device model name and understand which operating modes your device supports.

**STEP 2** Set time range from the pot No.3 in Z1A-ND30s Z1A-ND100s Set time range from the pots No.3 Z1T-ND-100s Z1T-ND-100s.2

Example → For t = 20 seconds → Set pot no.3 to 20s (Z1A-ND30s Z1A-ND100s)  
Example → For t = 100 seconds → Set pot no.3: t1 to 90s + t2 to 10s (Z1T-ND-100s Z1T-ND-100s.2)

Please disconnect the power before adjusting the timers, device will start with the new settings after connecting the power

**USER ASSISTANT**

**SETTING THE TIMER RELAY** Z1T-NDX

**STEP 1** Check the device model name and understand which operating modes your device supports.

**STEP 2** Select the desired time adjustment by the mode selection switches N.3 For more information review Table No.1 Set time range from the pots No.4 and No.5

Example → For t<sub>off</sub> = 60 minutes → Mode (1,2,3)=1, Mode(4,5,6,8)=0, Xt<sub>m</sub>=4, Xt<sub>a</sub>=4  
Time adjustment formula: t<sub>off</sub>: (t1+..+t8)xt<sub>m</sub>+t<sub>a</sub>

Please disconnect the power before adjusting the timers, device will start with the new settings after connecting the power

OFF (0)	1	2	3	4	5	6	7	8
ON (1)	1	2	3	4	5	6	7	8
	15	16	17	18	19	20	21	22

t<sub>off</sub>: (t1+..+t8)xt<sub>m</sub>+t<sub>a</sub>  
Table No.1

- » DIN normuna uygun YENİ 18 mm genişliğinde şık tasarım,
- » IEC 61812-1 standardına uygun + UL 508
- » Geniş çalışma gerilimi aralığı (12-240 V AC/DC),
- » SPDT röle çıkışı (10A),
- » Geniş ve kolay ayarlanabilir zaman aralığı,
- » LED bildirimler,
- » Yüksek hassasiyet ve anahtarlama dayanımı,
- » Yüksek mekanik dayanıklılık.

Ürün Adı	Sipariş No	Fonksiyon	Röle Sayısı	Zaman Ayarı
Z1A-ND30s	261025	ND	1 C/O	1 sn .. 30 sn
Z1A-ND100s	261023	ND	1 C/O	1 sn .. 100 sn
Z1T-ND100s	261010	ND	1 C/O	1 sn .. 100 sn
Z1T-PFD120m-24	261011	PFD	1 C/O	1 sn .. 120 dk
Z1T-PFD120s-24	261030	PFD	1 C/O	1 sn .. 120 sn
Z1T-NDX	261012	ND	1 C/O	0 sn .. 5109 sn
Z1T-FDF	261013	FDF	1 C/O	0.1 sn .. 10 gün
Z1T-NDF	261014	NDF	1 C/O	0.1 sn .. 10 gün
Z1T-ND100s.2	261026	ND	2 C/O	1 sn .. 100 sn



Besleme Gerilimi	12..240V AC/DC ±10% 24..240V AC/DC ±10% (Z1T-PFD120m-24, Z1T-PFD120m/s-24) 24V AC/DC (A2-A3 ve 180 .. 265V AC (A1-A3) (for Z1A-xxx)
Besleme Frekansı	45..65Hz
Güç Tüketimi	DC < 1.5 W < 8 W (for Z1T-PFD120m-24)
	AC < 5 VA < 8 VA (for Z1T-PFD120m-24)
Röle Çıkışları	Maksimum Anahtarlama Gerilim / Akım ( Güç) 115 VAC / 10A / 1250 VA 250VAC / 5 A / 1250 VA 250VAC / 16A / 4000 VA (Z1T-PFD120m/s-24)
Kablo Kesiti	2.5mm <sup>2</sup> / AWG 14-30 tek damarlı veya çok damarlı
Vida Sıkma Torku	0.5 Nm / 4.5 lb-inch
Kablo Soyma Boyutu (Min / Max)	8mm / 9mm
Çalışma Sıcaklığı Aralığı	-20 / +60 °C
Maksimum Çevre Sıcaklığı	60°C (55°C Z1T-PFD120m/s-24)
Koruma Derecesi (IEC 60529)	IP 20
Kirillik Derecesi	2

NOT : Z1T-PFD120m-24 ürünün şarj süresi 3sn ile 1 dk arasında, Z1T-PFD120s-24 ürünün şarj süresi ise 3 ile 10 sn arasında değişmektedir.

NOT : Yalnızca 60/75°C bakır (CU) kablo kullanınız.

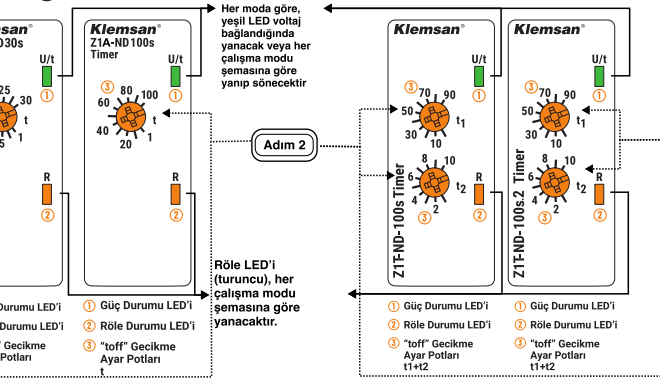
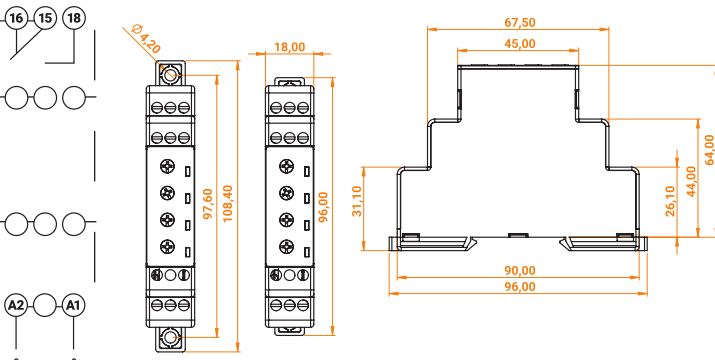

Adım 1

ÇALIŞMA MODU	FONKSİYON TANIMI	FONKSİYON AÇIKLAMASI
Mod : ND Çekme Gecikmesi	R: U/t:	Çıkış rölesi cihaz çalıştırıldığında enerjisiz konumdadır ve ayarlanan toff süresi bitiminde çeker.
Mod : FDF Kapalı Flaşör	R: U/t:	Çıkış rölesi cihaz çalıştırıldığında enerjisiz konumdadır ve ayarlanan ToFF süresi bitiminde çeker. Ayarlanan Ton süresi kadar iletimde kaldıktan sonra bırakır ve bu döngü böyle devam eder.
Mod : NDF Açık Flaşör	R: U/t:	Çıkış rölesi cihaz çalıştırıldığında çekili konumdadır ve ayarlanan ton süresi bitiminde bırakır. Ayarlanan toff süresi kadar enerjisiz kaldıktan sonra çeker ve bu döngü böyle devam eder.
Mod : PFD Güç Kapalı Bırakma Gecikmesi	Ready: R:	Cihaz, enerjilendiği anda çıkış rölesi aktif olur ve cihaz şarj olmaya başlar. Cihazın enerjisi kesildiği andan itibaren, ayarlanan t süresi sonunda çıkış rölesi deaktif olur.

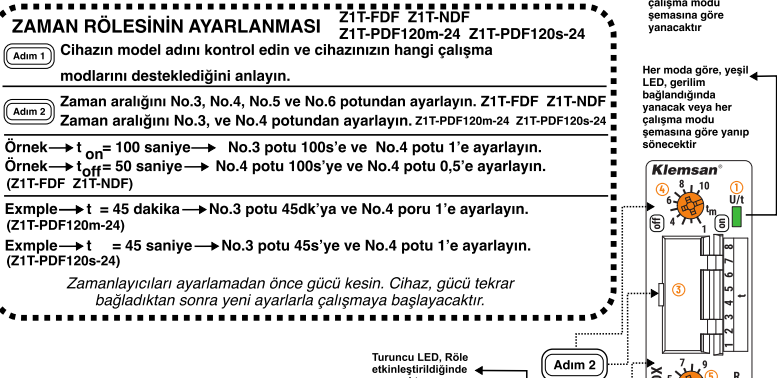
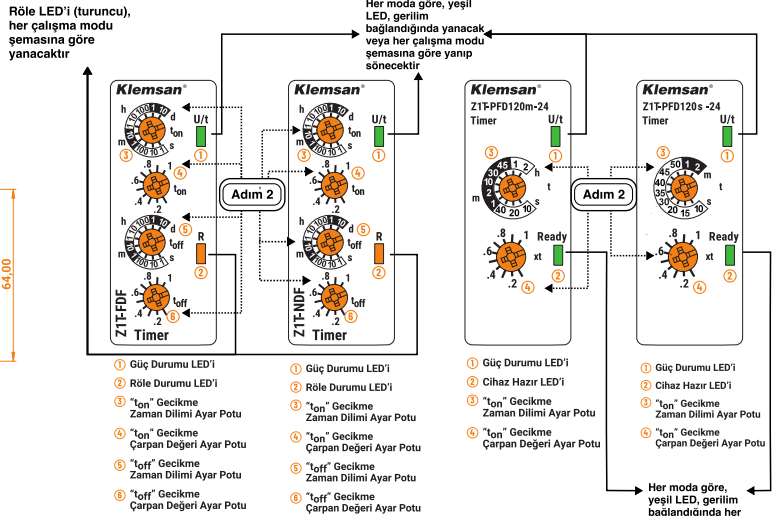

### ZAMAN RÖLESİNİN AYARLANMASI

**Z1A-ND30s Z1A-ND100s Z1T-ND-100s Z1T-ND-100s.2**

**Adım 1** Cihazın model adını kontrol edin ve cihazınızın hangi çalışma modlarını desteklediğini anlayın.

**Adım 2** Zaman aralığını No.3 potundan ayarlayın. Z1A-ND30s Z1A-ND100s Zaman aralığını No.3 potundan ayarlayın. Z1T-ND-100s Z1T-ND-100s.2

Örnek → t = 20 saniye için → No.3 potu = 20s (Z1A-ND30s Z1A-ND100s)

Örnek → t = 100 saniye için → No.3 potunda t1 = 90s + t2 = 10s (Z1T-ND-100s Z1T-ND-100s.2)

Zamanlayıcıları ayarlamadan önce gücü kesin. Cihaz, gücü tekrar bağladıktan sonra yeni ayarlarla çalışmaya başlayacaktır.

### ZAMAN RÖLESİNİN AYARLANMASI

**Z1T-NDX**

**Adım 1** Cihazın model adını kontrol edin ve cihazınızın hangi çalışma modlarını desteklediğini anlayın.

**Adım 2** İstenen zaman ayarını, No.3 numaralı mod seçim anahtarlarıyla seçin. Daha fazla bilgi için Tablo No.1'i inceleyin.

Zaman aralığını No.4 ve No.5 potundan ayarlayın.

Örnek → toff = 60 dakika için → Mod (1,2,3)=1, Mod (4,5,6,8)=0, Xt1m = 4, Xt1a = 4 Zaman ayarı formülü: toff: (t1+...+t8)xtm+ta

Zamanlayıcıları ayarlamadan önce gücü kesin. Cihaz, gücü tekrar bağladıktan sonra yeni ayarlarla çalışmaya başlayacaktır.

OFF (0)	1	2	3	4	5	6	7	8
ON (1)	11	12	13	14	15	16	17	18
	19	20	21	22	23	24	25	26

toff: (t1+...+t8)xtm+ta  
Table No.1